

## INSTALLATION INSTRUCTIONS FOR PROJECTION VIEWERS

(UltraVision – SuperVision – WideVision)

- 1- Need Power Drill, Hole Saw with pilot drill bit, small 1/8" drill bit, Tape Measure & carpenter's level
- 2- Use the tape measure to determine the best height to install the Viewer
- 3- Use the level to mark a horizontal line over the spot where you want the viewer installed, or place the installation label on the desired location.
- 4- Use the 1/8" starter bit to drill a small hole where the center of the opening will be and to drill any necessary holes to accommodate the spikes behind the outside cover of the Viewer.
- 5- Use the recommended hole saw to install the desired viewer. start slowly by placing the pilot drill over the previously drilled 1/8" hole
- 6- Start drilling from the outside of the door until the pilot drill protrudes lightly through the interior side of the door.
- 7- Remove the hole saw and go to the inside and finish drilling the hole out, taking care not to chip or splinter the door.
- 8- Disassemble the outer lens cover casing from the main body of the viewer by turning counterclockwise until it is off.
- 9- Insert the outer lens cover casing to the exterior side of the door with the spikes into the pre-drilled holes to set it flush with the door.
- 10- Insert the viewer main body into the hole from the inside of the door and turn clockwise while holding the outer cover in place until it is tightly held and the image is at level. Do not over tighten. Secure the viewer by turning the fastening ring until it is snug with the door surface.

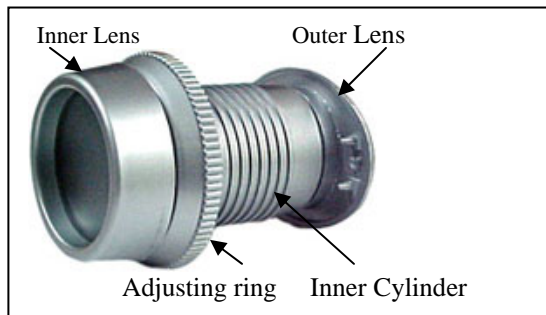

### Projection Door Viewers Overall Diameters:

Model	Inner Lens Cover	Adjusting Ring	Inner Cylinder*	Door Width** Minimum - Maximum
<b>UltraVision-A</b>	62mm (2 7/16")	67mm (2 5/8")	60mm (2 3/8")	1.0 - 1 3/4
<b>UltraVision</b>	63mm (2 1/2")	65mm (2 3/4")	60mm (2 3/8")	1.0 - 1 3/4
<b>SuperVision</b>	58mm (2 1/4")	60mm (2 3/8")	45mm (1 3/4")	1.0 - 1 3/4
<b>WideVision</b>	55mm (2 1/8")	60mm (2 3/8")	36mm (1 1/2")	3/4 - 1 1/2

All measurements are approximate. Confirm all measurements before installation

- \*The inner cylinder size determines the bore size needed for installation
- \*\*The width range of the door required for the installation of the Viewer.

## REQUIREMENTS FOR INSTALLATION OF PROJECTION VIEWERS UltraVision – SuperVision – WideVision

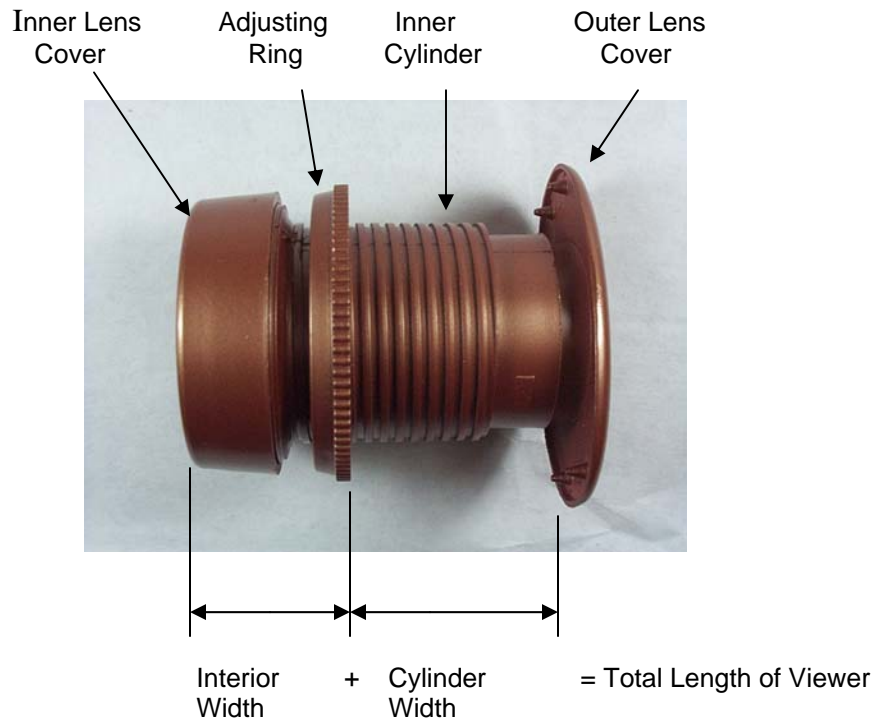

### Standard Dimensions for Flush Mounting

Model	Total Length of Viewer	Ideal door width for flush mount	Interior Width Extending out
<b>UltraVision-A</b>	72mm (2 7/8")	50mm (1 7/8")	23mm (7/8")
<b>UltraVision</b>	72mm (2 7/8")	50mm (1 7/8")	23mm (7/8")
<b>SuperVision</b>	73mm (2 7/8")	45mm (1 3/4")	28mm (1 1/8")
<b>WideVision</b>	67mm (2 5/8")	41mm (1 5/8")	26mm (1.0")

To calculate the length that the Interior Width will extend from the surface of the door, you should subtract the width of your door from the Total Length of the door viewer.

*For example, if your door is 35mm (1 3/8") thick and you wanted to install the SuperVision that has a Total Length of 73mm (2 7/8") you will calculate: 73mm – 35mm = 38mm (1 1/2")*

The above table shows the **minimum** amount that the Interior Width will extend from the door for your reference. The length of the extension does not affect the performance of the viewer; it is only a cosmetic choice.

## INFORMATION ABOUT WIDE ANGLE DOOR VIEWERS

Thank you for purchasing a Projection Door Viewer. You should expect many years of enjoyment, performance, and protection from this sophisticated device.

The design of all Projection Door Viewers available in the market today utilizes the principle of a projected image. A prism projects the image onto the rear screen of an opaque lens. This is a projected image, very much like in a "rear projection TV".

When looking at the image projected onto the opaque lens, it will show as a reversed image. Like a mirror, the left side of the subject will be on the right side and vice-versa. This is not a fault of the device, but due to an optical principle.

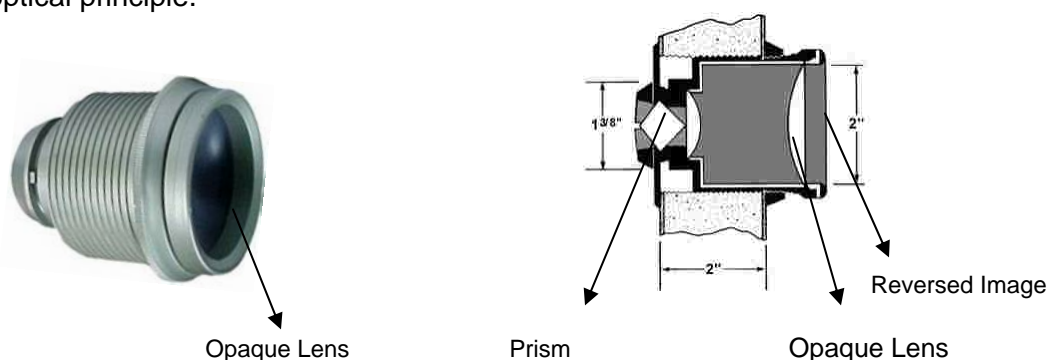

The brightness of the picture is dependent on the intensity of the light source on the subject. Therefore, if you look at the viewer installed on a door leading to a bright open area, the image will be sharp and clear; however, if the viewer is located in a dim or darker area, like in a poorly lit hall of an apartment building, the image will be dark, fuzzy, and will lack definition.

This is why during a bright sunny day outdoors, the image will be very bright and sharp when looking from inside the house, but fuzzy on a cloudy day. One way to increase the source of light available during darker days, is to install a brighter porch or flood light over the subject outside the door. The purpose is to have the outside light source brighter than the light source inside the house.

Another consideration is to test the door viewer behind a barrier before installation, not just held on the hand in an open area. You will need some darkness from the inside in order to view the outside projected image properly. This is similar to trying to view a movie in plain daylight at a drive-in, the image projected on the screen will be faded and very dark, and however, at nighttime the movie will be much brighter and sharper under the stars.

If the door opens to a dark or poorly lit area that you cannot improve, an alternative solution will be to install a direct thru-the-lens viewer such as the EZView series. These door viewers will offer a larger viewing area than conventional peepholes. you will be able to view the image directly like a viewfinder with little lost of brightness or sharpness.

## XTRASCOPE AND XTRASCOPE PLUS INSTALLATION

- 1- Locate best position to install the door viewer. Ideally at eye level
- 2- Drill a hole of diameter 15mm for the XtraScope or 19mm for the XtraScope Plus
- 3- Adjust the viewer to the width of the door by turning the cylinders as required
- 4- Remove the outside lens cylinder counter clockwise and install the lens from the outside.
- 5- Turn the outer lens clockwise while holding the inner cylinder from the inside of the door until it is tight.

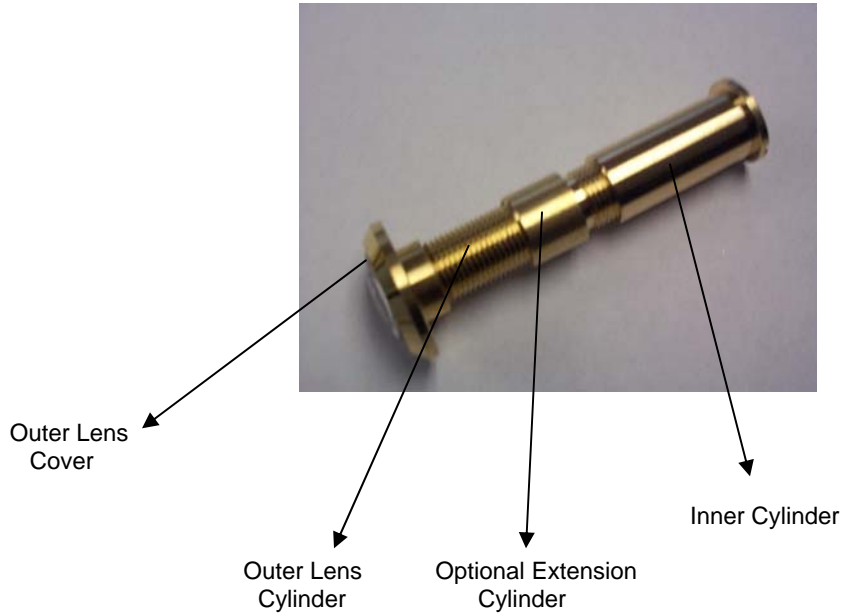

MODEL	OUTER LENS COVER	OUTER LENS CYLINDER	INNER CYLINDER*	DOOR WIDTH
XTRASCOPE (brass)	26 mm (1.0")	12 mm (1/2")	14 mm (9/16")	35 – 55 mm (1 3/8" – 2 1/8")
XTRASCOPE W/ 1 EXT (brass)	26mm (1.0")	12mm (1/2")	14mm (9/16")	45 – 75mm (1 3/4" - 2 7/8")
XTRASCOPE W/ 2 EXT (brass)	26 mm (1.0")	12 mm (1/2")	14 mm (9/16")	55 - 90 mm (2 1/8" – 3 1/2")
XTRASCOPE PLUS (brass)	30 mm (1 3/8")	12 mm (1/2")	18 mm (3/4")	52 -115 mm (2 1/8" – 4 1/2")
XTRASCOPE PLUS (silver)	30mm (1 3/8")	12mm (1/2")	17mm (5/8")	70mm - 110mm (2 3/4"- 4 3/8")

All measurements are approximate. Confirm all measurements before installation

- The dimension of the Inner Cylinder will determine the size of the bore required
- XtraScope UL listed R13709 fire rated 1.5 hrs

## Installation Instructions for Door Viewers Including Overall Dimensions

- 1- Locate the best position to install the door viewer. Ideally at eye level (approx 5.0')
- 2- Drill a 1/8" pilot hole completely through the door
- 3- Drill a hole as determined by the size of the Inner Cylinder halfway through the door from each side
- 4- Disassemble the door viewer and install the Outer lens from the outside
- 5- Turn the outer lens clockwise while holding the Inner Lens cover from inside the door until the viewer is tight

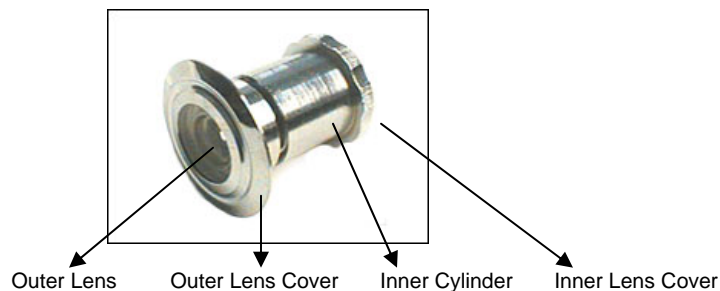

**Door Viewer / Scopes Overall Diameters**

MODEL	OUTSIDE LENS COVER	INNER CYLINDER*	INNER LENS COVER	DOOR WIDTH**
NuScope	35mm (1 3/8")	26mm (1 1/16")	35mm (1 3/8")	1 1/4" – 2.0"
ZScope	35mm (1 3/8")	26mm (1 1/16")	35mm (1 3/8")	1 1/4" – 2.0"
MiniScope	26mm (1.0")	14mm (9/16")	17mm (11/16")	3/4" – 1 3/8"
XtraScope	26mm (1.0")	14mm (9/16")	17mm (11/16")	1 3/8" – 2 1/8"
MiniView	24mm (15/16")	24mm (15/16")	28mm (1 1/8")	1/2" – 1 3/8"
MicroScope	16mm (5/8")	12mm (1/2")	15mm (9/16")	1/2" – 3/4"
EZView	35mm (1 3/8")	26mm (1 1/16")	35mm (1 3/8")	1 3/8" – 2 1/8"
EZView-BR	35mm (1 3/8")	26mm (1 1/16")	35mm (1 3/8")	1 1/2" – 2 1/2"
EZViewEX	35mm (1 3/8")	26mm (1 1/16")	35mm (1 3/8")	2 3/4" – 3 1/2"
EZViewXL	35mm (1 3/8")	26mm (1 1/16")	35mm (1 3/8")	1 7/8" – 2 3/4"
EZview-LL	40mm (1 9/16")	28mm (1 1/8")	40mm (1 9/16")	5 3/8" – 8.0"
EZView2	35mm (1 3/8")	26mm (1 1/16")	35mm (1 3/8")	1 1/2" - 2 1/8"
EZViewex2	35mm (1 3/8")	26mm (1 1/16")	35mm (1 3/8")	2 7/8" – 3 1/2"

All measures are approximate. Confirm all measurements before installation.  
XtraScope, MiniScope, MiniView UL listed R13709, fire rated 1.5 hrs

- \* The inner cylinder size determines the opening bore size required.
- \*\* The width range of the door required for proper installation